

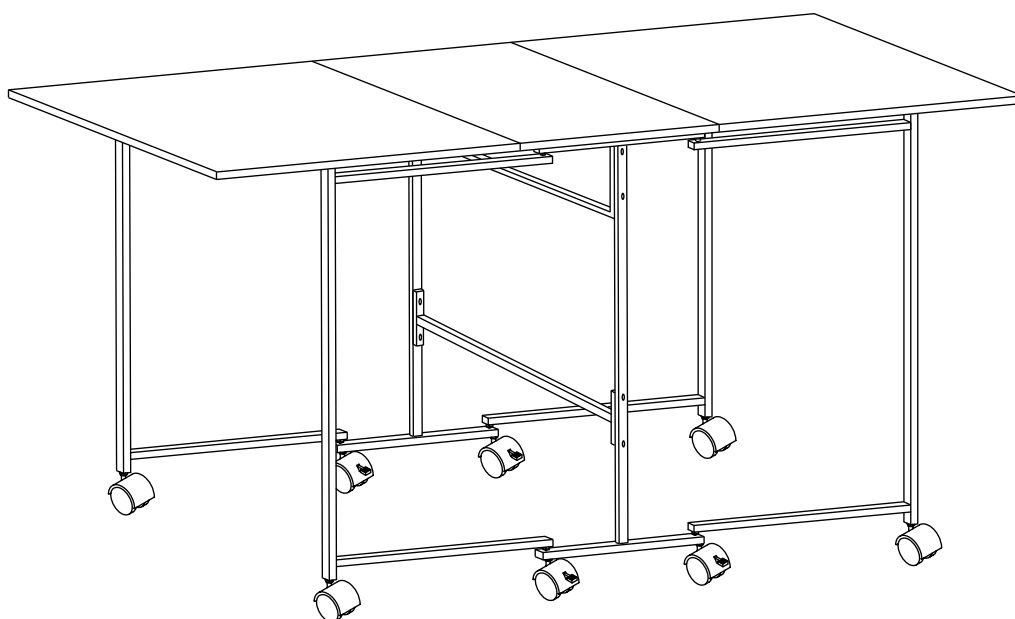

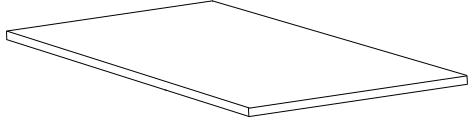

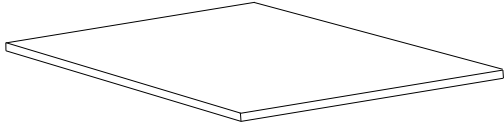

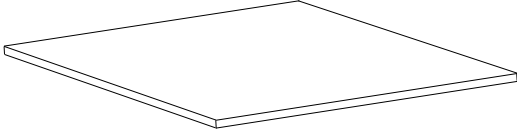
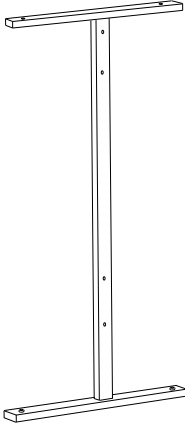
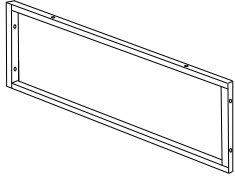
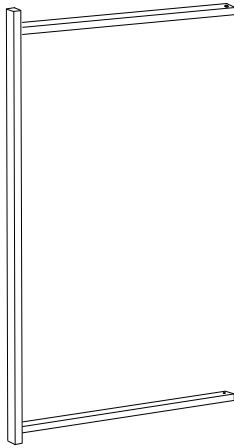
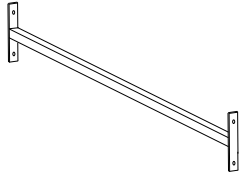
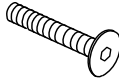

JO-ANN STORES INC

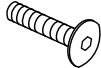
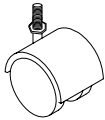

Article 160-5294  
Cutting Table

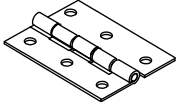
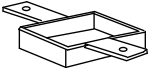
CUSTOMER SERVICE NUMBER: 1-888-857-3862  
[www.goodsupport.com](http://www.goodsupport.com)

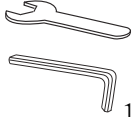
<p><b>A</b> Top middle panel</p>  <p>1 PC</p>	<p><b>B</b> Left top side panel</p>  <p>1 PC</p>		
<p><b>C</b> Right top side panel</p>  <p>1 PC</p>	<p><b>D</b> Side upright</p>  <p>2 PCS</p>		
<p><b>E</b> Tie frame</p>  <p>1 PC</p>	<p><b>F</b> Pivoting leg</p>  <p>4 PCS</p>		
<p><b>G</b> Tie bar</p>  <p>1 PC</p>		<p>(1) Screw</p>  <p>1/4" x1-5/8" 8 PCS</p>	<p>(2) Nut</p>  <p>1/4" 8 PCS</p>
<p>(5) Screw</p>  <p>1/8" x1" 2 PCS</p>		<p>(3) Washer</p>  <p>24 PCS</p>	<p>(4) Screw</p>  <p>1/8" x1-3/8" 4 PCS</p>
<p>(6) Screw</p>  <p>1/4" x1-1/8" 8 PCS</p>	<p>(7) Wheel</p>  <p>4 PCS</p>	<p>(8) Locking wheel</p>  <p>4 PCS</p>	<p>(9) Hinge</p>  <p>6 PCS</p>
	<p>(10) Stopper</p>  <p>4 PCS</p>	<p>(11) Screw</p>  <p>1/8" x1/2" 44 PCS</p>	<p>(12) Wrench tool</p>  <p>1 PC</p>

## STEP 1

1. Attach locking wheel (8) to side upright (D) using wrench tool (12) as shown.
2. Attach tie frame (E) to side upright (D) using screw (1), nut (2), washer (3) and wrench tool (12) as shown.
3. Attach tie bar (G) to side upright (D) using screw (1), nut (2), washer (3) and wrench tool (12) as shown.

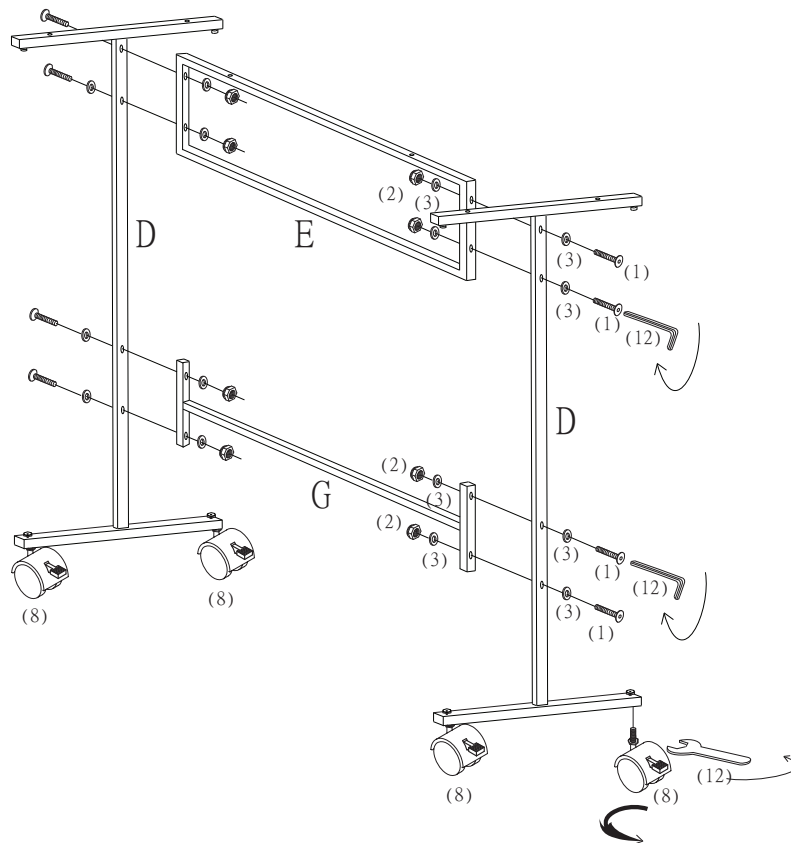

## STEP 2

Attach top middle panel (A) to side upright (D) and tie frame (E) using screw (4) and (5) as shown.

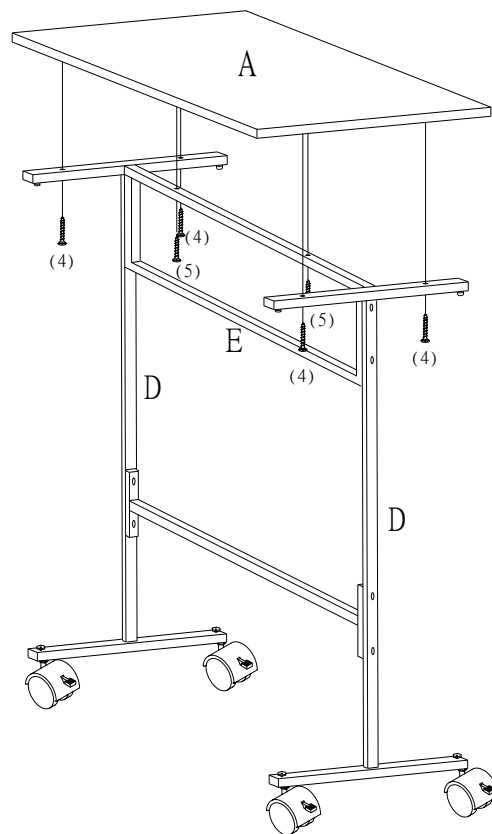

## STEP 3

1. Attach wheel (7) to pivoting leg (F) using wrench tool (12) as shown. (Pivoting leg (F) needs to be assembled with the holes on the legs facing down so the wheels can be applied.)
2. Attach pivoting leg (F) to side upright (D) using washer (3) and screw (6) as shown.

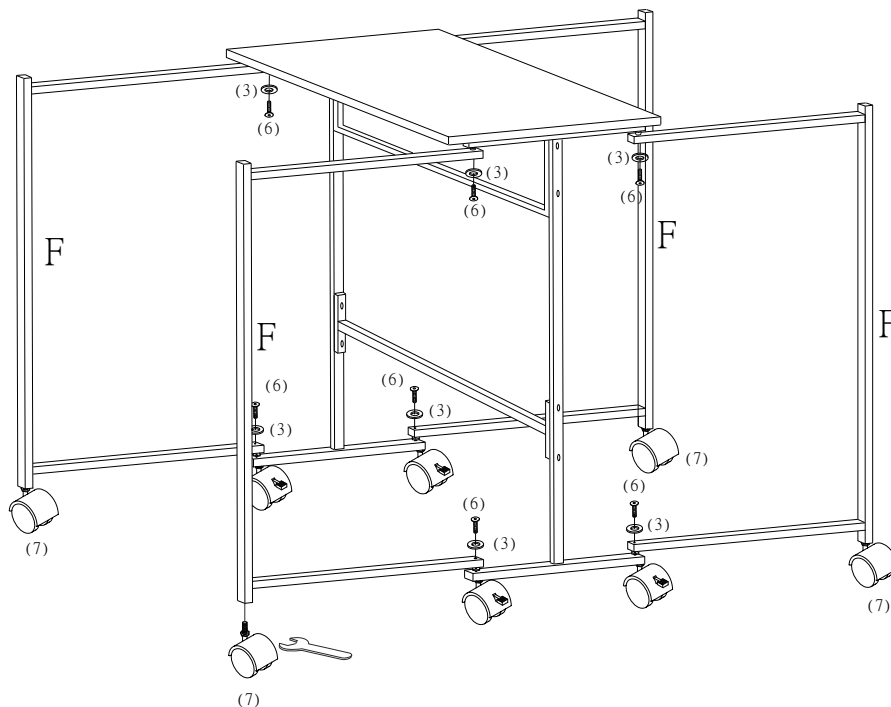

## STEP 4

1. Attach stopper (10) to the back of left top side panel (B) and right top side panel (C) using screw (11) as shown.
2. Attach left top side panel (B) and right top side panel (C) to top middle panel (A) using hinge (9) and screw (11) as shown.
3. Completed.

